

OUTPUT	POLE	SYN. SPEED	VOLT.	FREQ	INSUL.	TIME RATING	MODEL	FRAME NO.
5HP	2P	3600 R.P.M	230/460 ^V	60 ^{Hz}	F	CONT.	TEFC	184T
	4P	1800 R.P.M						

- * FOR DIRECT COUPLING
- * COLOR: MUNSELL RAL 5010
- * IP55

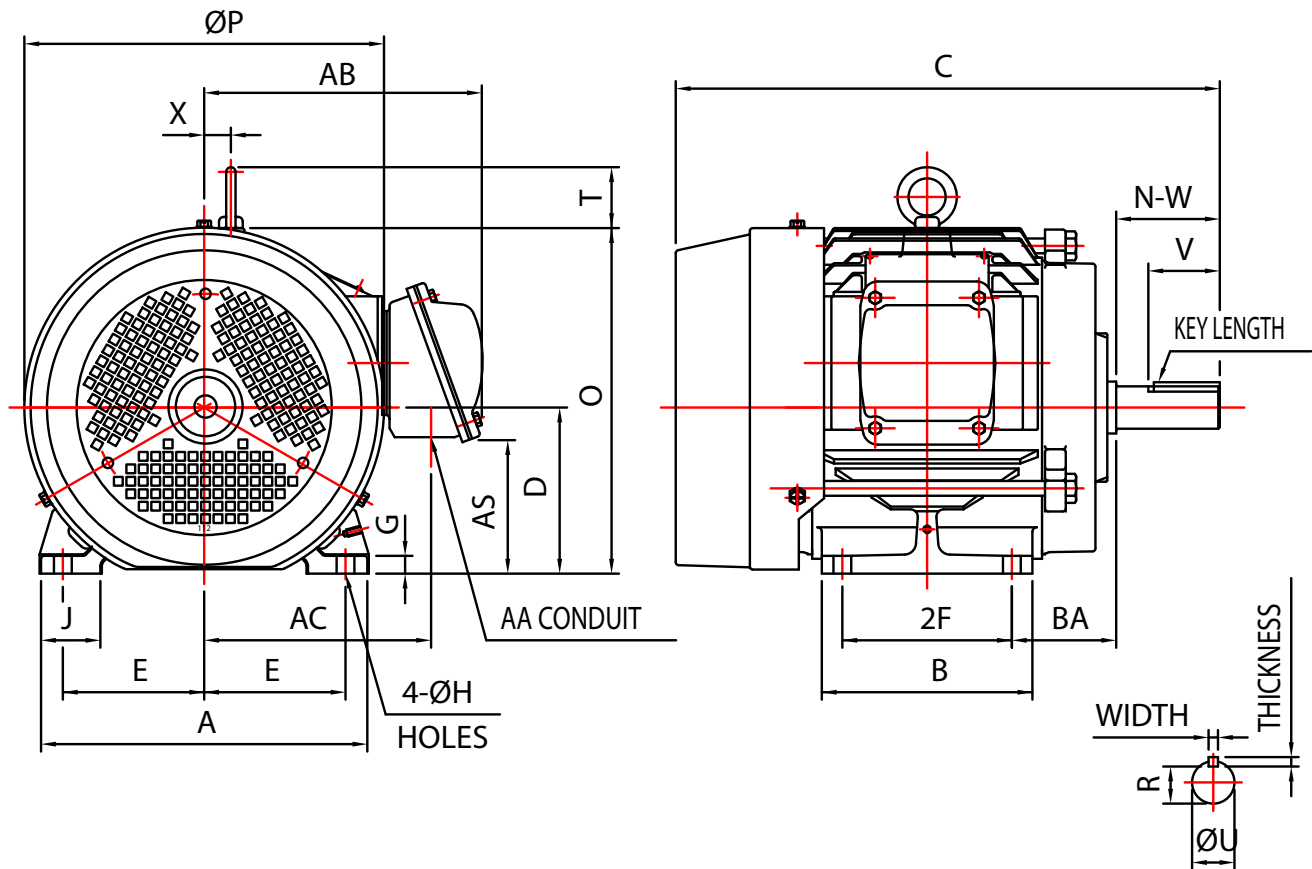

MOUNTING				A	B	C	D	G	J	O	T	P	X
E	2F	H	BA										
3.75	5.50	0.41	2.75	8.66	6.61	15.42	4.50	0.56	1.57	9.27	1.63	9.55	0.71

AC	KEY			KEYSEAT	CONDUIT BOX			SHAFT EXTENSION			BEARING NO.		APR. WT. (LBS.)
	WIDTH	THICKNESS	LENGTH	R	AS	AA	AB	N-W	U	V	D.E	O.D.E	
5.91	0.250	0.250	1.750	0.986	3.71	NPT3/4"	7.32	2.75	1.125	2.70	6207zz	6206zz	120

NOTE: 1. TOLERANCE OF SHAFT END DIAMETER U: +0.000inch, -0.0005inch
 2. TOLERANCE OF SHAFT CENTER HEIGHT D: +0.00inch, -0.03inch