

| OUTPUT | POLE | SYN. SPEED R.P.M | VOLT. V | FREQ Hz | INSUL. | TIME RATING | MODEL | FRAME NO. |
|--------|------|---------------------|------------|------------|--------|-------------|-------|-----------|
| 5HP | 4P | 1800 | 230/460 | 60 | F | CONT. | TEFC | #184TC |

- * FOR DIRECT COUPLING
- * COLOR: MUNSELL RAL 5010
- * IP55

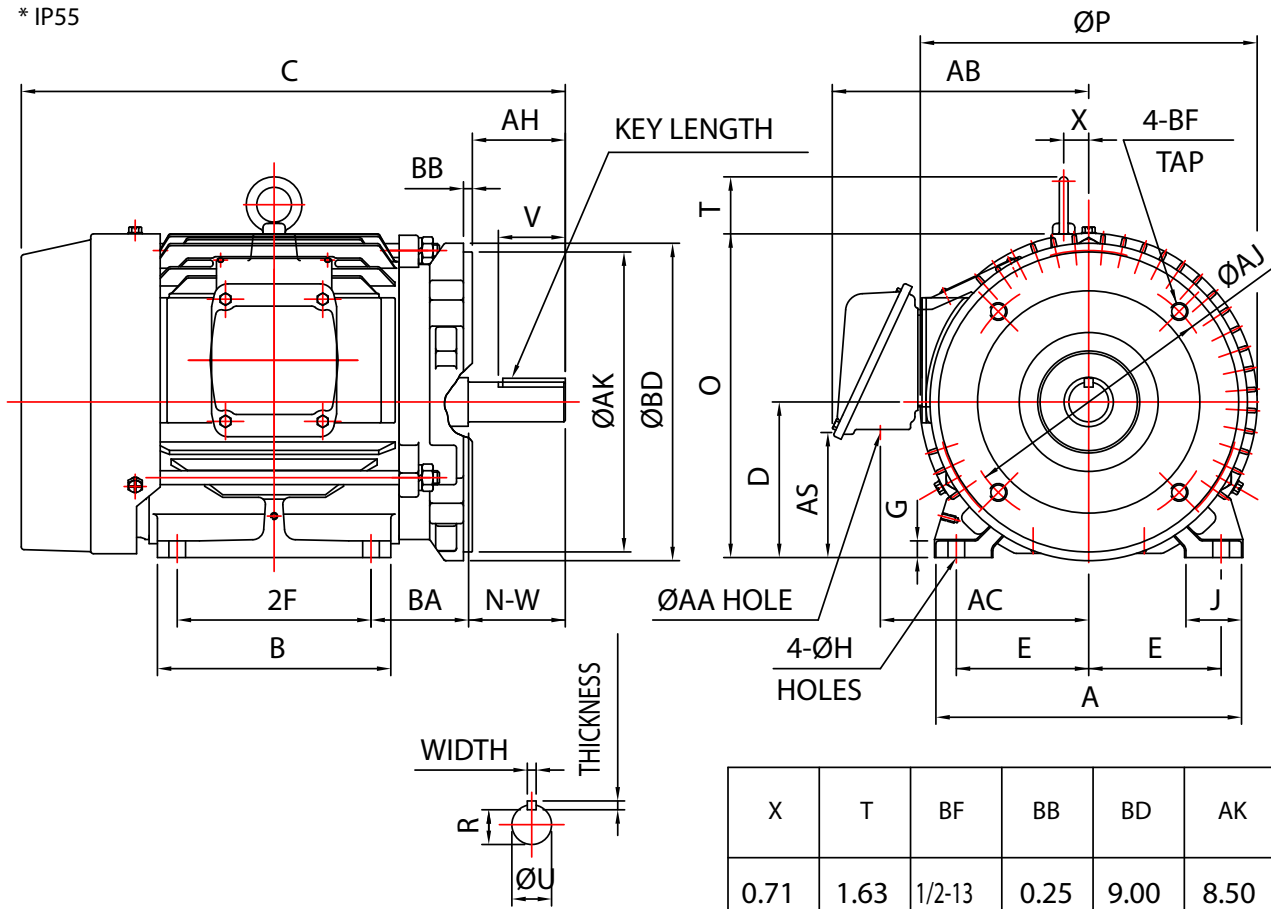

| MOUNTING | | | | A | B | C | D | G | J | O | AH | P | AJ |
|----------|-------|-----------|--------|---------|-------------|---------|------|-----------------|-------|------|-------------|--------|-----------------|
| E | 2F | H | BA | | | | | | | | | | |
| 3.75 | 5.50 | 0.41 | 2.75 | 8.66 | 6.61 | 15.42 | 4.50 | 0.56 | 1.57 | 9.27 | 2.62 | 9.55 | 7.250 |
| AC | KEY | | | KEYSEAT | CONDUIT BOX | | | SHAFT EXTENSION | | | BEARING NO. | | APR. WT. (LBS.) |
| | WIDTH | THICKNESS | LENGTH | R | AS | AA | AB | N-W | U | V | D.E | O.D.E | |
| 5.91 | 0.250 | 0.250 | 1.750 | 0.986 | 3.71 | NPT3/4" | 7.32 | 2.75 | 1.125 | 2.70 | 6207zz | 6206zz | 122 |

NOTE: 1. TOLERANCE OF SHAFT END DIAMETER U: +0.000inch, -0.0005inch
 2. TOLERANCE OF SHAFT CENTER HEIGHT D: +0.00inch, -0.003inch