

| OUTPUT | POLE | SYN. SPEED | VOLT. | FREQ | TIME RATING | MODEL | FRAME NO. |
|--------|------|------------|----------|------|-------------|-------|-----------|
| 30HP | 4P | 1800 | 230/460V | 60HZ | CONT. | TEFC | 286T |

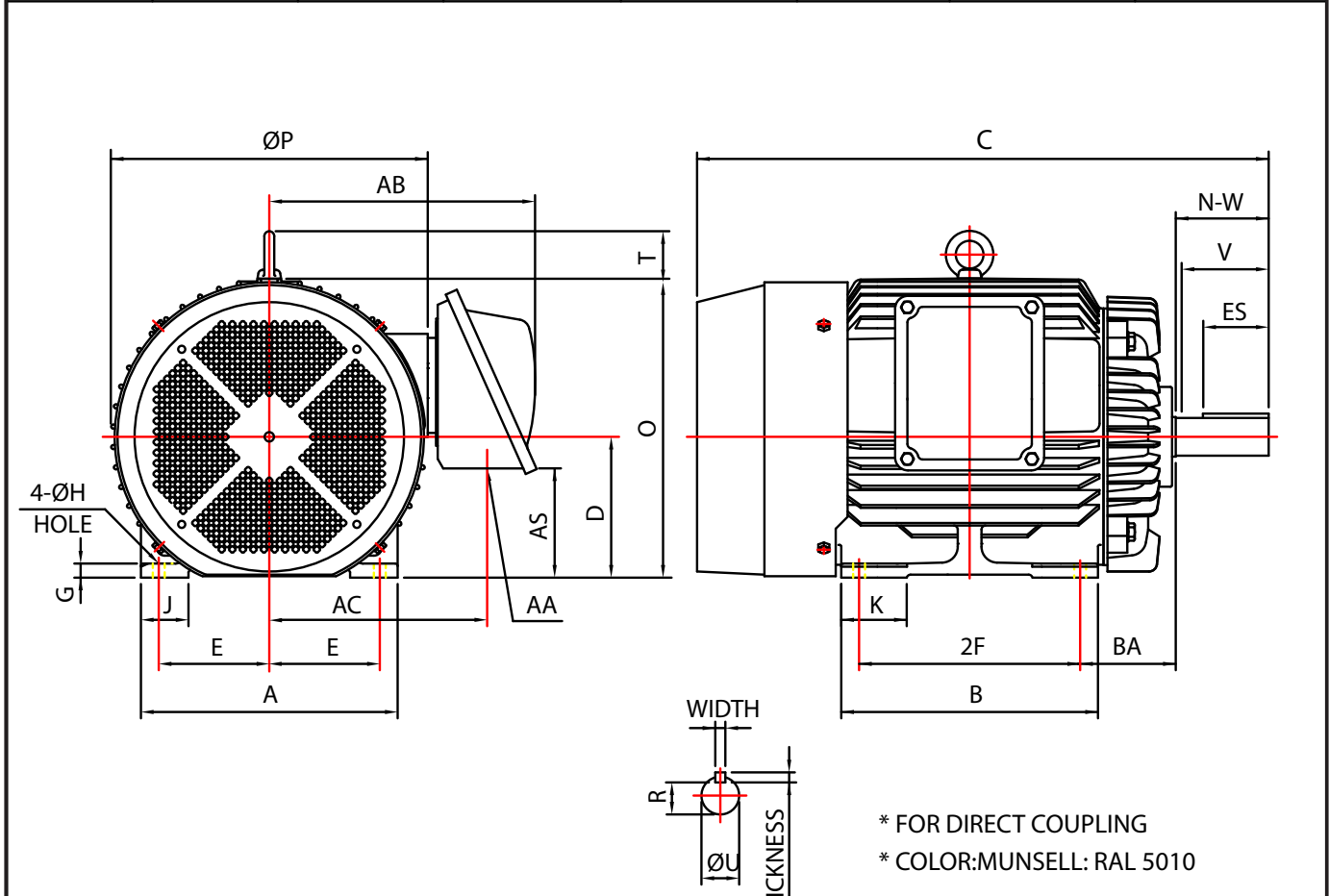

* FOR DIRECT COUPLING
* COLOR:MUNSELL: RAL 5010
* IP55

| MOUNTING | | | | | | | | | | | | | E | 2F | H | BA | A | B | C | D | G | J | K | P | AA | AB |
|----------|--|--|--|--|--|--|--|--|--|--|--|--|------|------|------|------|-------|-------|------|-----|------|------|------|-------|---------|------|
| | | | | | | | | | | | | | 5.50 | 11.0 | 0.53 | 4.75 | 12.76 | 12.76 | 28.4 | 7.0 | 0.79 | 2.36 | 3.25 | 15.67 | NPT1.5" | 13.4 |

| AC | AS | O+T | KEY | | ES | KEYSEAT | | SHAFT EXTENSION | | | BEARING NO. | | APPROX WEIGHT |
|------|------|------|-------|-----------|------|---------|------|-----------------|------|--------|-------------|---------|---------------|
| | | | WIDTH | THICKNESS | | R | N-W | U | V | D.E | O.D.E | | |
| 11.0 | 4.13 | 17.3 | 0.500 | 0.500 | 3.25 | 1.591 | 4.62 | 1.875 | 4.50 | 6310ZZ | 6210ZZ | 513 LBS | |

NOTE:1. TOLERANCE OF SHAFT END DIAMETER U: +0.000,-0.001
 2. TOLERANCE OF SHAFT CENTER HEIGHT D: +0.000,-0.06
 3. DIMENSION R TOLERANCE: +0.000,-0.015
 4. DIMENSION V IS LENGTH OF STRAIGHT PART OF SHAFT.
 5. CLASS INSULATION.