

OUTPUT	POLE	SYN. SPEED	VOLT.	FREQ	TIME RATING	MODEL	FRAME NO.
50HP	4P	1800	230/460V	60HZ	CONT.	TEFC	326T

* FOR DIRECT COUPLING
 * COLOR:MUNSELL: RAL 5010
 * IP55

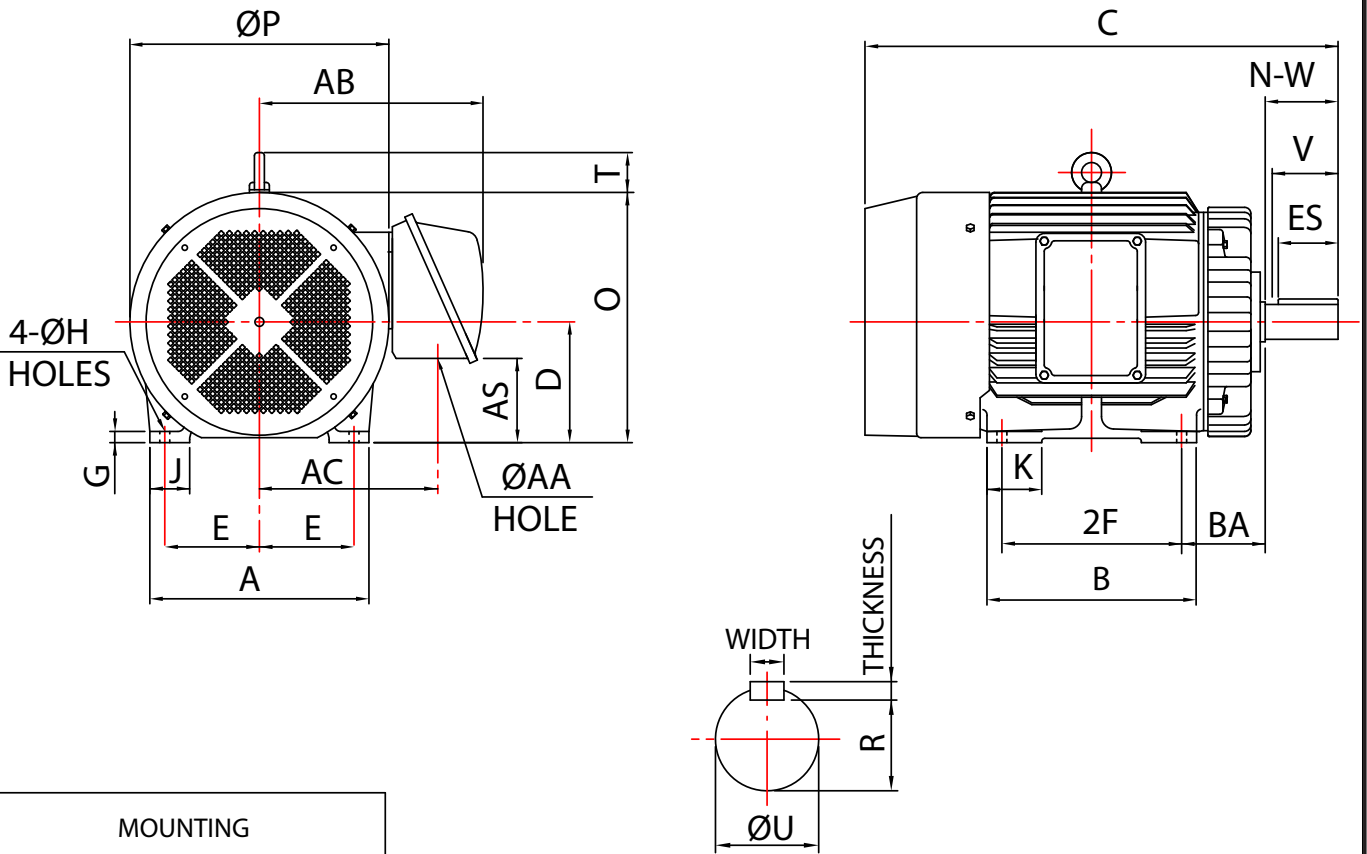

MOUNTING

E	2F	H	BA	A	B	C	D	G	J	K	P	AA	AB
6.25	12.00	0.66	5.25	14.88	14.17	31.32	8.00	0.91	3.15	3.15	17.32	NPT2"	14.37

AC	AS	O+T	KEY		KEYSEAT	SHAFT EXTENSION			BEARING NO.		APPROX WEIGHT	
			WIDTH	THICKNESS		ES	R	N-W	U	V		D.E
11.73	5.44	19.13	0.500	0.500	3.875	1.845	5.25	2.125	5.00	6312	6212	726Lb

NOTE:1. TOLERANCE OF SHAFT END DIAMETER U: +0.000,-0.001
 2. TOLERANCE OF SHAFT CENTER HEIGHT D: +0.000,-0.06
 3. DIMENSION R TOLERANCE: +0.000,-0.015
 4. DIMENSION V IS LENGTH OF STRAIGHT PART OF SHAFT.
 5. F CLASS INSULATION.