

| Torque Ft.-Lbs. | Clamping Force - Lbs |
|-----------------|----------------------|
| 14              | 1349                 |
| 29              | 1798                 |
| 43              | 3822                 |
| 57              | 5395                 |
| 72              | 7194                 |
| 87              | 8992                 |
| 116             | 10791                |

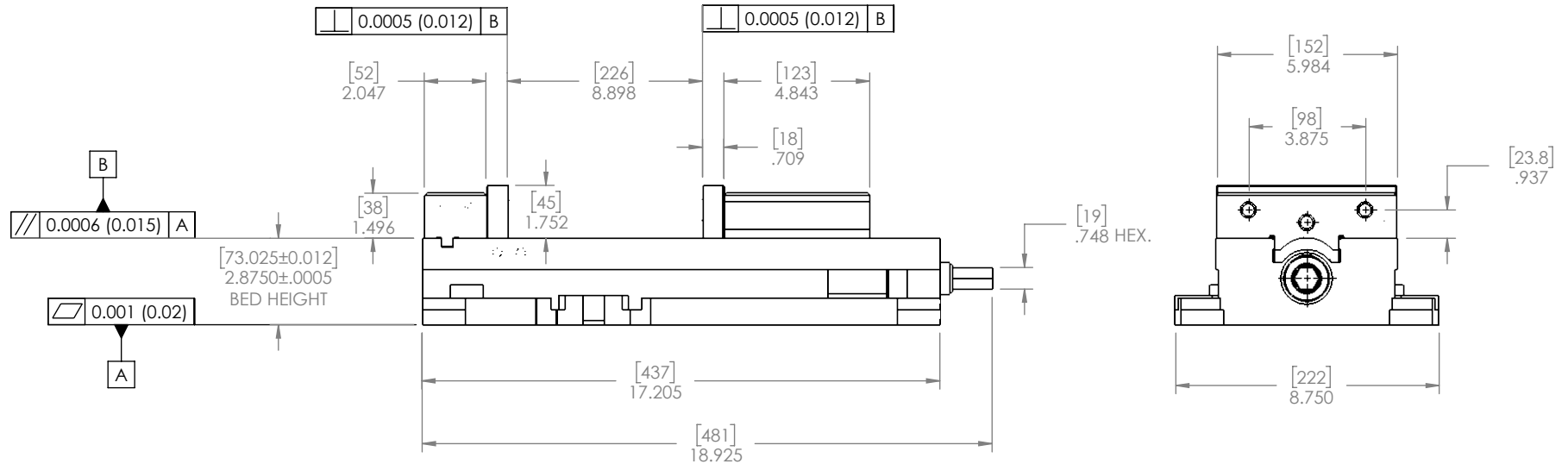

NOTES:  
 MATERIAL:  
 BODY: DUCTILE IRON  
 JAWS: HARDENED STEEL  
 WEIGHT: 80 LBS

|  |           |  |      |
|--|-----------|--|------|
| MATERIAL:  | SEE NOTES | NAME   | DATE |
| HARDNESS:  | 45 HRC    | FINISH:  |      |
| <b>CONTACT INFORMATION:</b><br>Toll Free 855-869-2425<br>Fax 508-653-5110<br>www.tmxtools.com<br>34 TALBOT ROAD<br>NORTH BOROUGH, MA 01532 USA |           | DRAWN T.T. 02-21-2020<br>ENG APPR. T.T. 02-21-2020<br>MFG APPR.<br>Q.A. APPR.<br>SALES APPR.   |      |
| <br>THIRD ANGLE PROJECTION   |           | <b>CONFIDENTIAL</b><br>THIS DRAWING AND THESE SPECIFICATIONS ARE THE SOLE PROPERTY OF TOOLMEX INDUSTRIAL SOLUTIONS. AND SHALL NOT BE REPRODUCED, OR COPIED IN PART OR AS A WHOLE WITHOUT THE EXPRESS WRITTEN PERMISSION OF TOOLMEX INDUSTRIAL SOLUTIONS IS PROHIBITED. |      |

**tmx**™  
 SOLE PROPERTY OF  
 TOOLMEX INDUSTRIAL SOLUTIONS

TITLE  
 6" MILLING MACHINE VISE, 9" JAW OPENING

|      |            |     |
|------|------------|-----|
| SIZE | DWG. NO.   | REV |
| A    | 3-220-0068 | D   |

DO NOT SCALE DRAWING

SHEET 1 OF 1