

| Torque Ft.-Lbs | Clamping Force - Lbs |
|----------------|----------------------|
| 14 | 2248 |
| 29 | 3147 |
| 43 | 4496 |
| 57 | 6295 |
| 72 | 8093 |
| 87 | 9442 |
| 116 | 10791 |

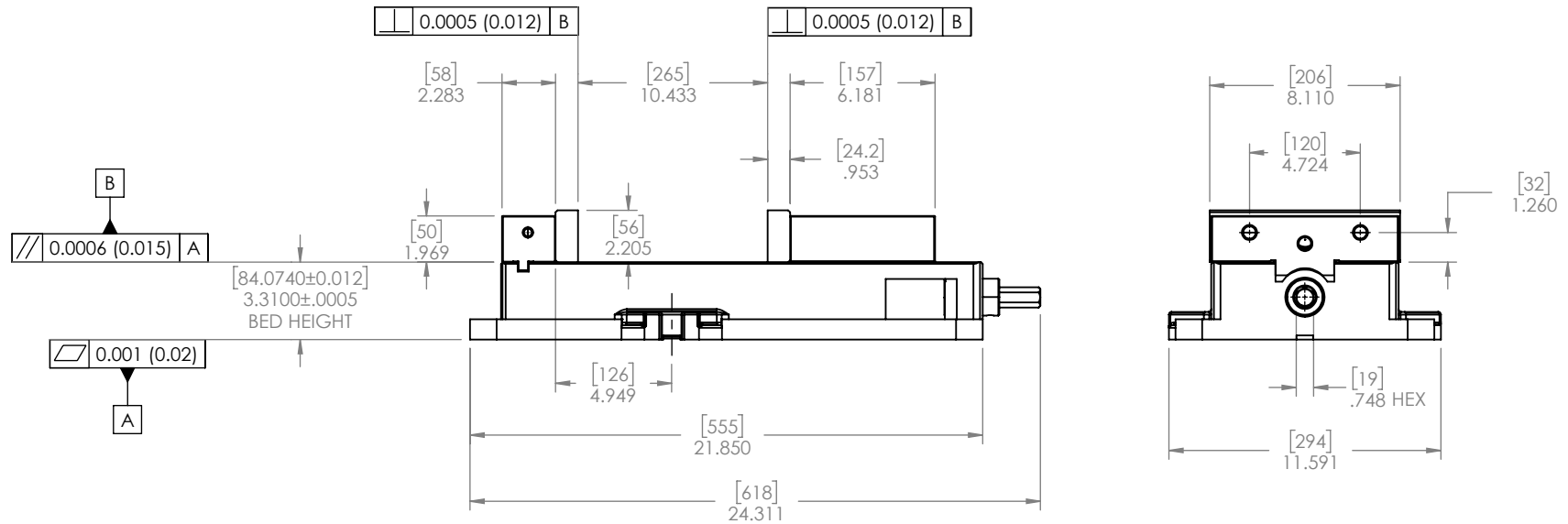

NOTES:

MATERIAL:
 BODY: DUCTILE IRON
 JAWS: HARDENED STEEL
 WEIGHT: 150 LBS

| | | | |
|--|-----------|--|--|
| MATERIAL: | SEE NOTES | NAME | DATE |
| HARDNESS: | 45 HRC | FINISH: | |
| CONTACT INFORMATION: Toll Free 855-869-2425 Fax 508-653-5110 www.tmxtools.com 34 TALBOT ROAD NORTH BOROUGH, MA 01532 USA | | DRAWN T.T. 02-21-2020 ENG APPR. T.T. 02-21-2020 MFG APPR. Q.A. APPR. SALES APPR. | tmx™ SOLE PROPERTY OF TOOLMEX INDUSTRIAL SOLUTIONS TITLE 8" MILLING MACHINE VISE, 10" JAW OPENING SIZE A DWG. NO. 3-220-0081 REV D |
| THIRD ANGLE PROJECTION | | CONFIDENTIAL THIS DRAWING AND THESE SPECIFICATIONS ARE THE SOLE PROPERTY OF TOOLMEX INDUSTRIAL SOLUTIONS, AND SHALL NOT BE REPRODUCED, OR COPIED IN PART OR AS A WHOLE WITHOUT THE EXPRESS WRITTEN PERMISSION OF TOOLMEX INDUSTRIAL SOLUTIONS IS PROHIBITED. | |

| | | | |
|----------------------|--|--------------|--|
| DO NOT SCALE DRAWING | | SHEET 1 OF 1 | |
|----------------------|--|--------------|--|