

Torque Ft.-Lbs.	Clamping Force - Lbs
14	899
29	2698
43	4047
57	5620
72	7194
87	8992
101	10791

NOTES:

MATERIAL:
 BODY: DUCTILE IRON
 JAWS: HARDENED STEEL
 WEIGHT: 68.2 LBS

PERPENDICULARITY (BETWEEN RUNNING FACE AND JAW PLATE): 0.0012 (0.030)

PARALLELISM (KEYWAYS ON BOTTOM OF BED TO JAW PLATE): 0.0008 (0.020)

MATERIAL:	SEE NOTES	NAME	DATE
HARDNESS:	45 HRC	FINISH:	
CONTACT INFORMATION:			
Toll Free 855-869-2425 Fax 508-653-5110			
www.tmxtools.com			
34 TALBOT ROAD NORTH BOROUGH, MA 01532 USA			

DRAWN	T.T.	02-24-2020
ENG APPR.	T.T.	02-24-2020
MFG APPR.		
Q.A. APPR.		
SALES APPR.		

tmx™
 SOLE PROPERTY OF
 TOOLMEX INDUSTRIAL SOLUTIONS

TITLE
 6" WELLOCK VERSATILE VISE

SIZE	DWG. NO.	REV
A	3-227-006	F

CONFIDENTIAL
 THIS DRAWING AND THESE SPECIFICATIONS ARE THE SOLE PROPERTY OF TOOLMEX INDUSTRIAL SOLUTIONS. AND SHALL NOT BE REPRODUCED, OR COPIED IN PART OR AS A WHOLE WITHOUT THE EXPRESS WRITTEN PERMISSION OF TOOLMEX INDUSTRIAL SOLUTIONS IS PROHIBITED.



THIRD ANGLE PROJECTION

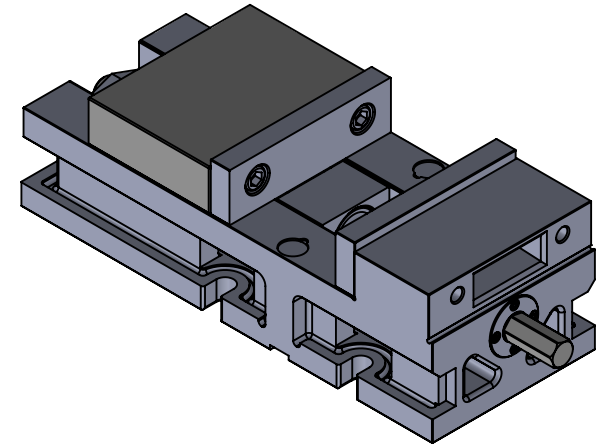
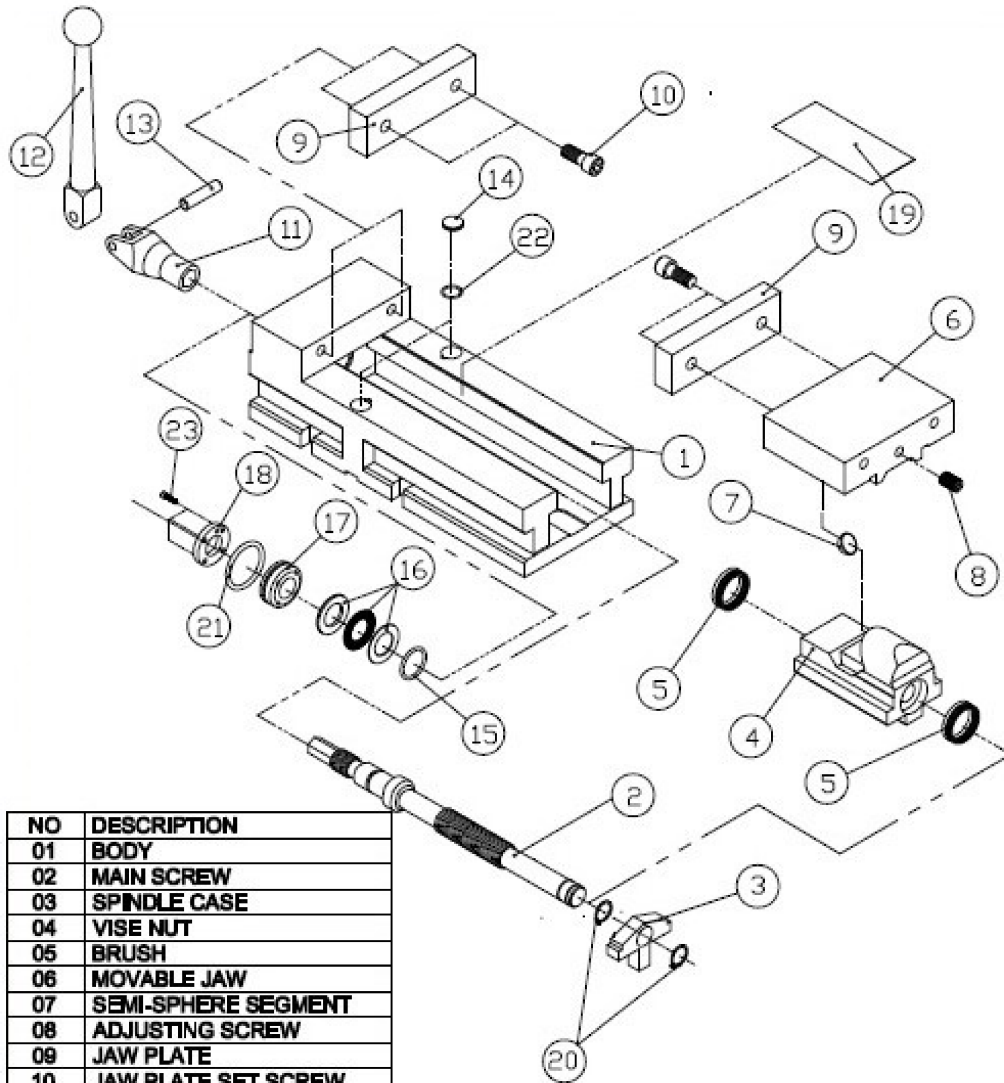

NO	DESCRIPTION
01	BODY
02	MAIN SCREW
03	SPINDLE CASE
04	WISE NUT
05	BRUSH
06	MOVABLE JAW
07	SEMI-SPHERE SEGMENT
08	ADJUSTING SCREW
09	JAW PLATE
10	JAW PLATE SET SCREW
11	HANDLE SOCKET
12	HANDLE BAR
13	PIN
14	CHIP COVER
15	O-RING
16	BEARING THRUST COLLAR
17	LOCKING SCREW NUT
18	STABLE SCREW NUT
19	SLIDE COVER
20	C-RING
21	O-RING
22	O-RING
23	SCREW

MATERIAL:	SEE NOTES		NAME	DATE
HARDNESS:	45 HRC	FINISH:	DRAWN	T.T. 02-24-2020
<u>CONTACT INFORMATION:</u>			ENG APPR.	T.T. 02-24-2020
Toll Free 855-869-2425 Fax 508-653-5110			MFG APPR.	
www.tmxtools.com			Q.A. APPR.	
34 TALBOT ROAD NORTH BOROUGH, MA 01532 USA			SALES APPR.	
CONFIDENTIAL				
THIS DRAWING AND THESE SPECIFICATIONS ARE THE SOLE PROPERTY OF TOOLMEX INDUSTRIAL SOLUTIONS. AND SHALL NOT BE REPRODUCED, OR COPIED IN PART OR AS A WHOLE WITHOUT THE EXPRESS WRITTEN PERMISSION OF TOOLMEX INDUSTRIAL SOLUTIONS IS PROHIBITED.				
 THIRD ANGLE PROJECTION				

tmx ™			SOLE PROPERTY OF TOOLMEX INDUSTRIAL SOLUTIONS	
TITLE 6" WELLOCK VERSATILE VISE				
SIZE	DWG. NO.			REV
A	3-227-006			F
DO NOT SCALE DRAWING			SHEET 2 OF 2	