

3-825-2520P

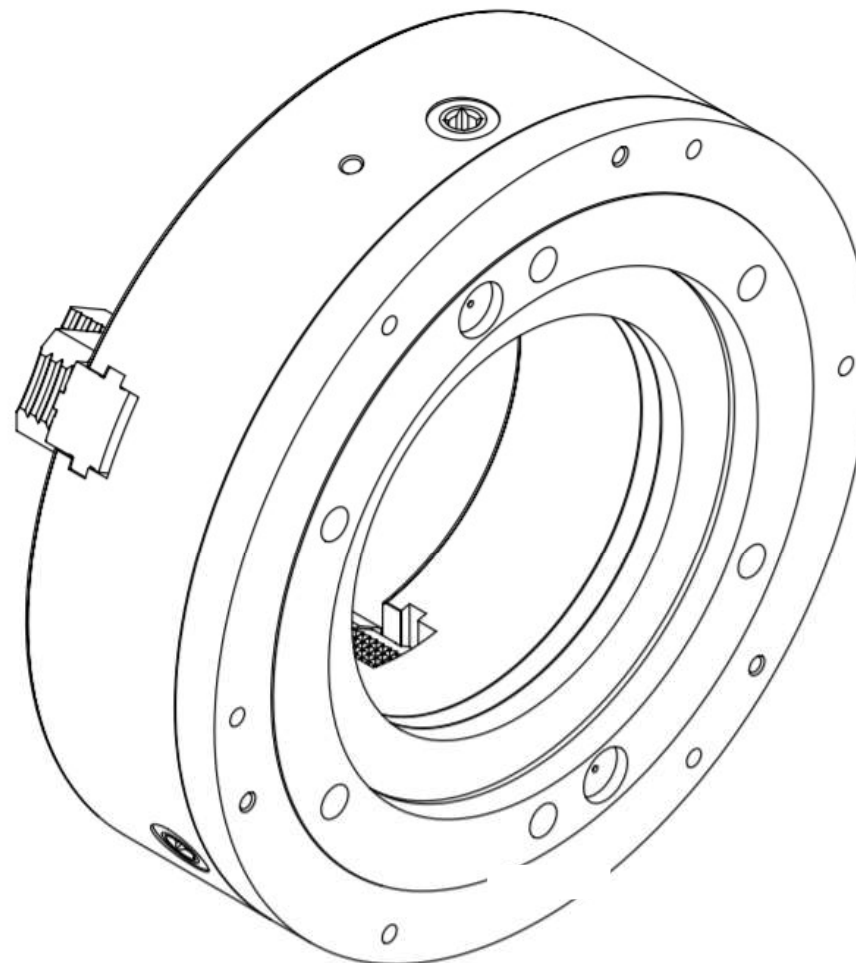

Chuck Technical Specifications

Max. R.P.M.	970
Max. torque on key:	60 daN.m.
Gripping force:	3750 daN
Weight:	650 lbs (approx.)
Material	Steel
Number of Jaws	3

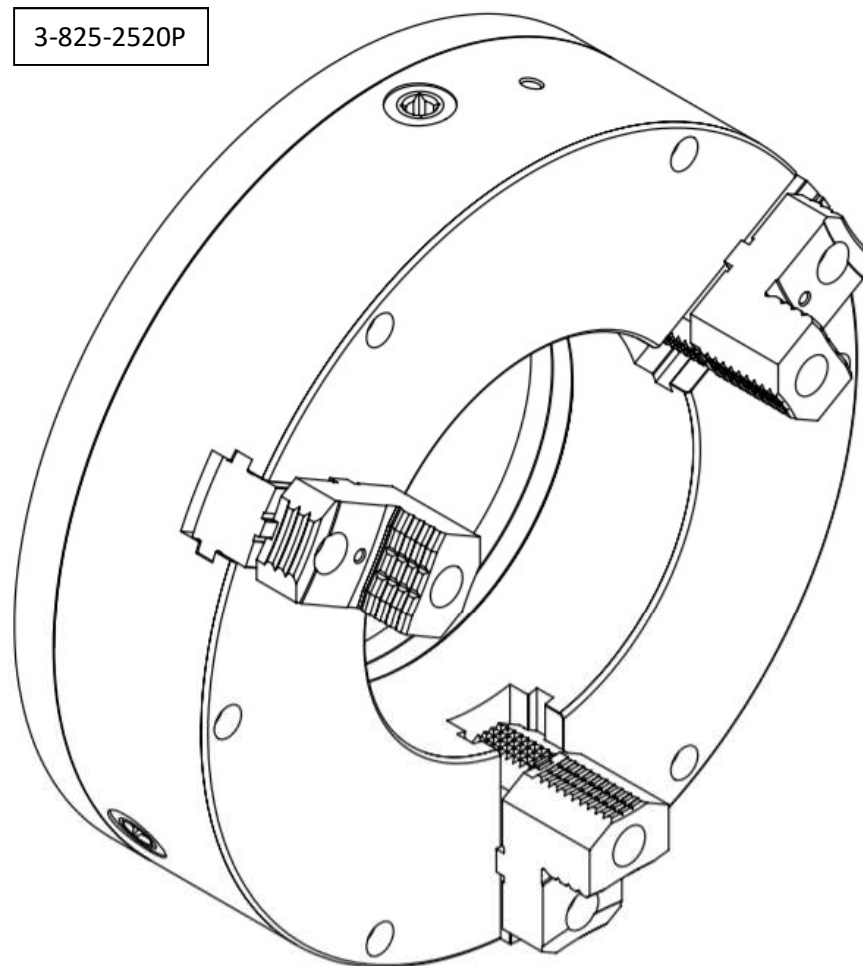
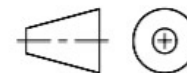

3-825-2520P

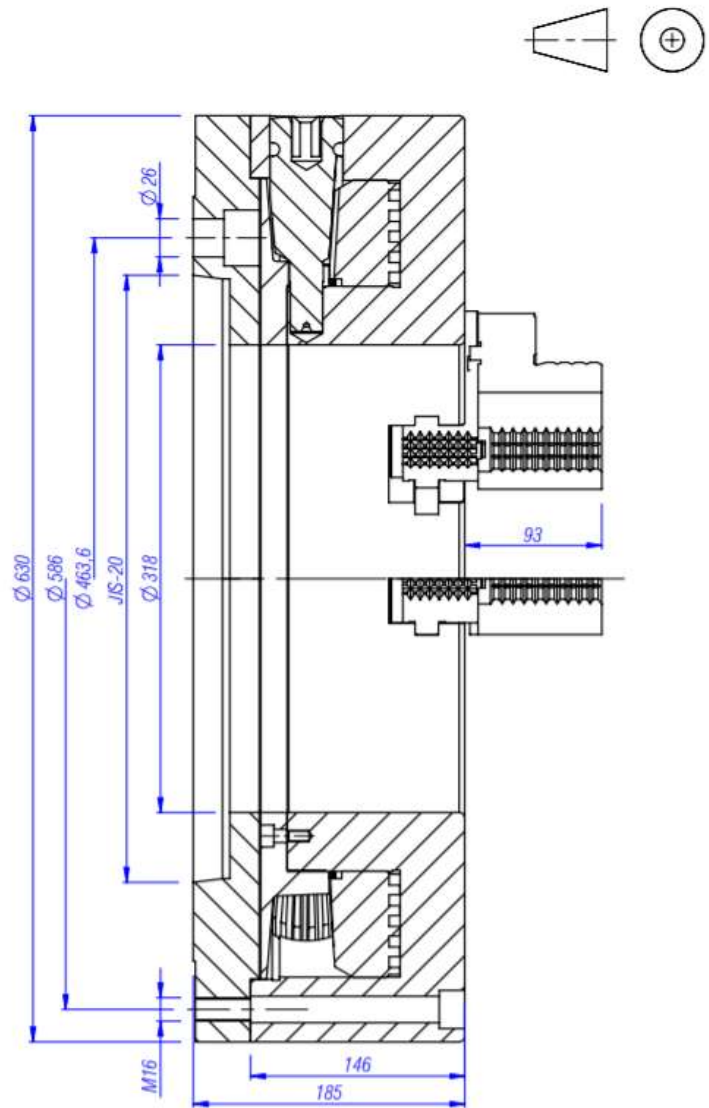
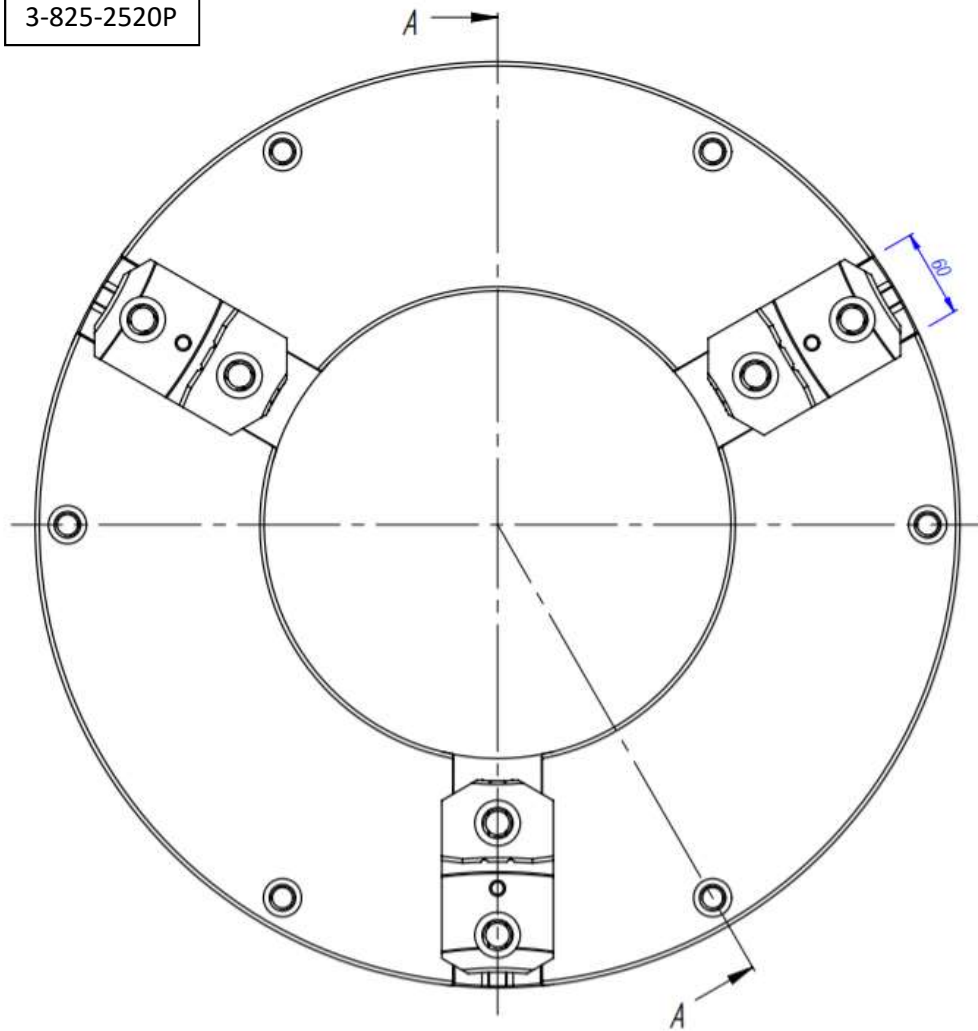

tmxTM
EUROPEAN PRECISION & QUALITY