

8 7 6 5 4 3 2 1

D

C

B

A

D

C

B

A

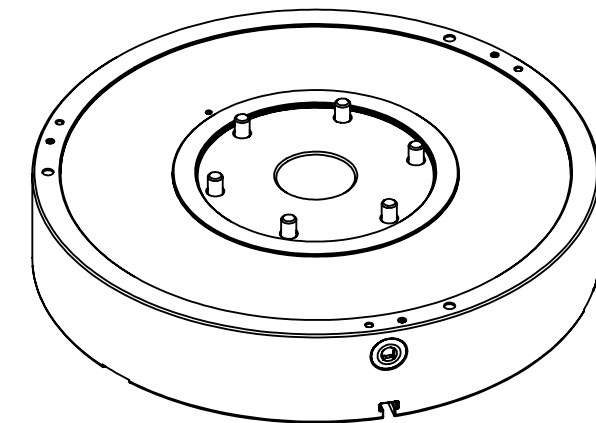
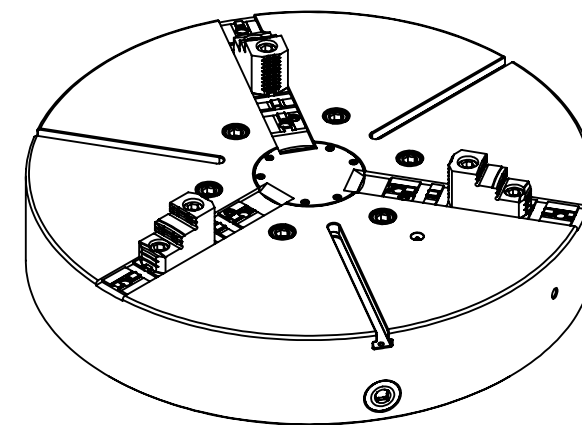
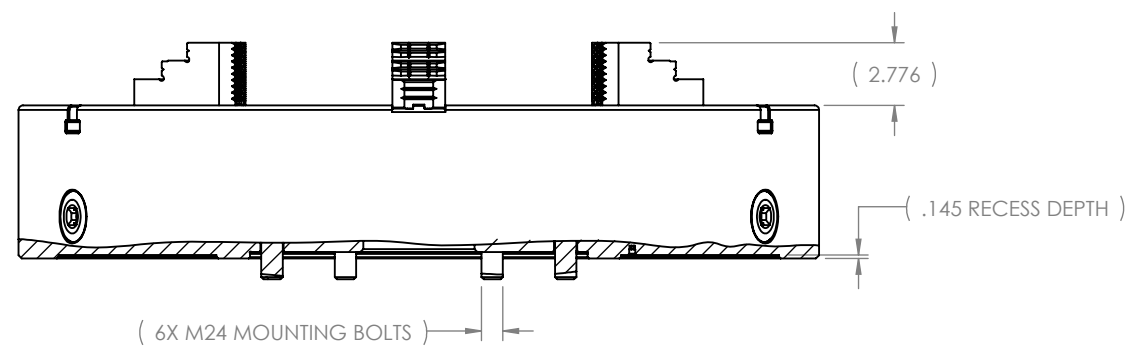
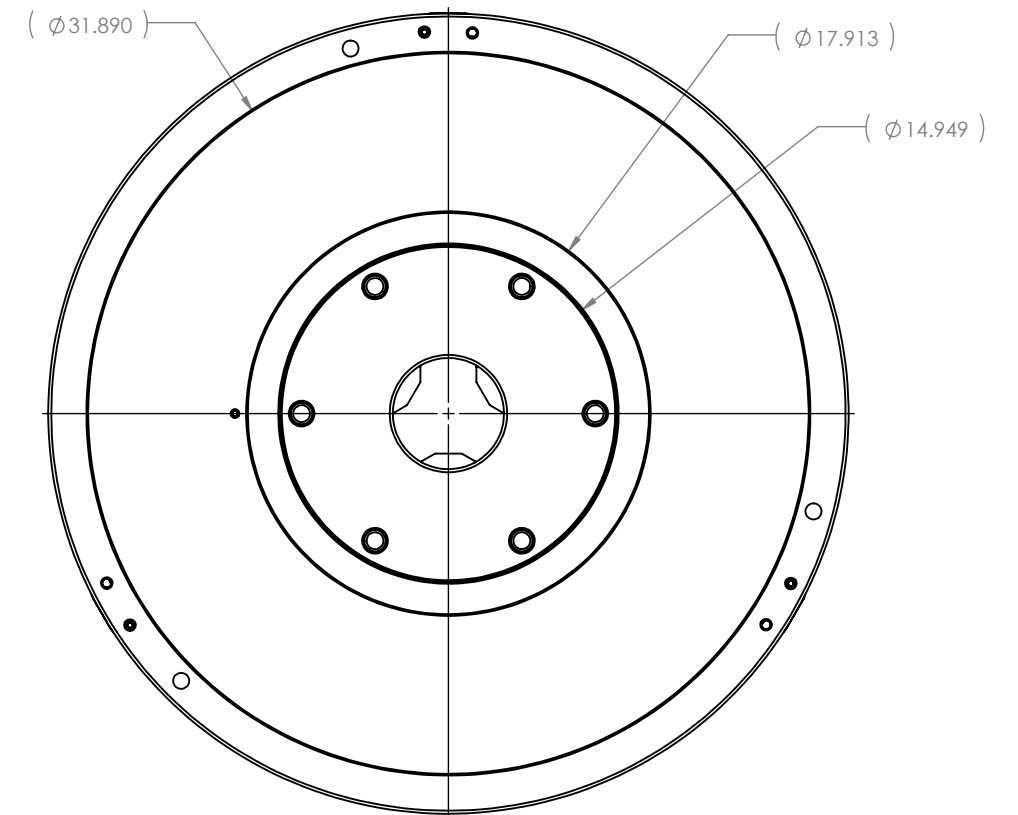
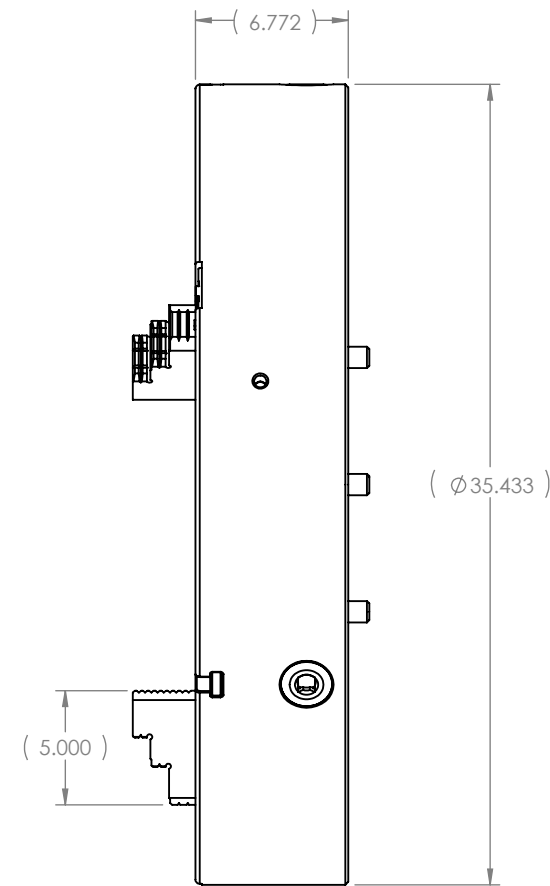
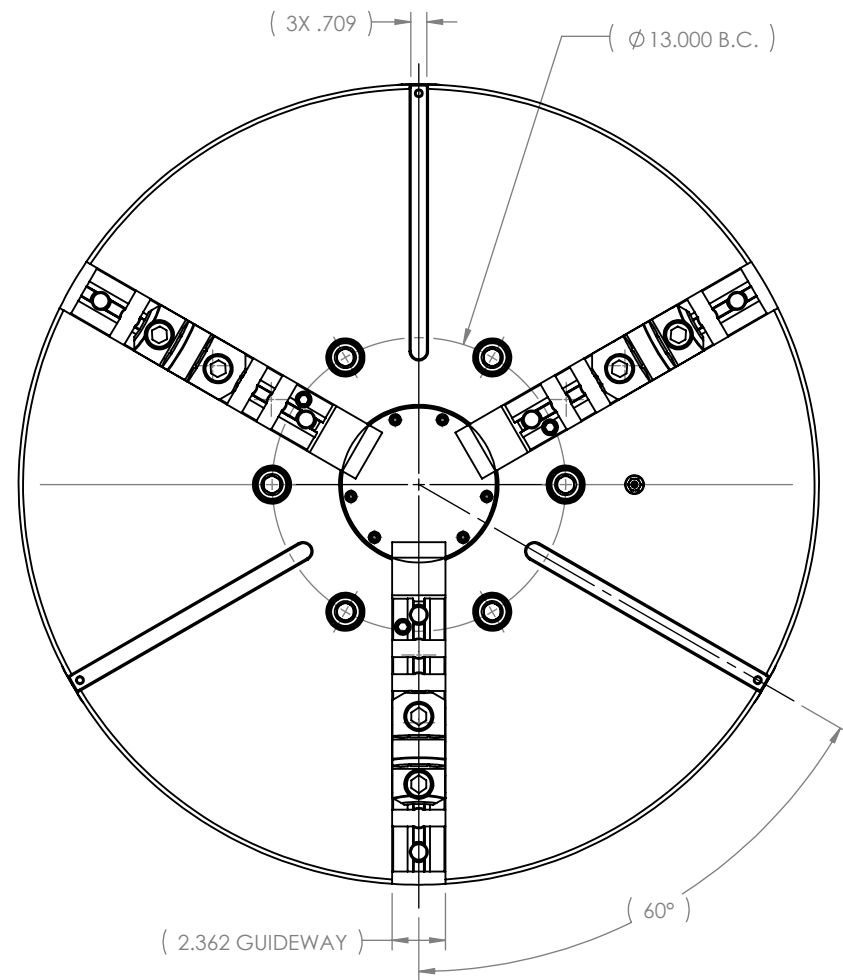

NOTES:

WEIGHT: 1246 LBS
 GRIPPING FORCE: 11500 daN
 MAX. SPEED: 679 RPM
 MAX. TORQUE: 80 daNm
 MIN. CLAMPING RANGE: 7.09
 MAX. CLAMPING RANGE: 35.43

MATERIAL: FORGED STEEL	NAME	DATE	TOOLMEX™ SOLE PROPERTY OF TOOLMEX INDUSTRIAL SOLUTIONS	
HARDNESS:	FINISH:	DRAWN T. THACH 08-28-2020		
CONTACT INFORMATION: Toll Free 855-869-2425 Fax 508-653-5110 www.tmxtools.com 34 TALBOT ROAD NORTH BOROUGH, MA 01532 USA				TITLE 3 JAWS (2-PC) SCROLL VTL CHUCK, 36IN (900mm)
INTERPRET GEOMETRIC TOLERANCING PER: Y1999-2001				SIZE DWG. NO. REV B 3-826-3600P A
THIRD ANGLE PROJECTION			CONFIDENTIAL THIS DRAWING AND THESE SPECIFICATIONS ARE THE SOLE PROPERTY OF TOOLMEX INDUSTRIAL SOLUTIONS, AND SHALL NOT BE REPRODUCED, OR COPIED IN PART OR AS A WHOLE WITHOUT THE EXPRESS WRITTEN PERMISSION OF TOOLMEX INDUSTRIAL SOLUTIONS IS PROHIBITED.	
		DO NOT SCALE DRAWING	SHEET 1 OF 1	

8 7 6 5 4 3 2 1