

3-859-2420P

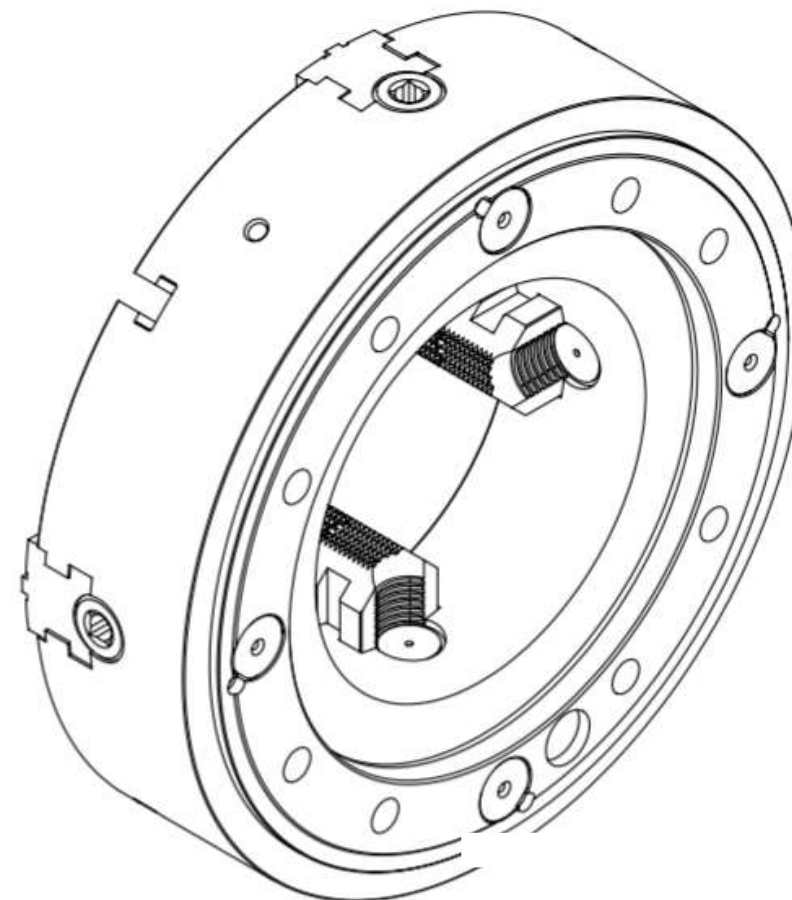

Chuck Technical specifications

Max. R.P.M.	970
Gripping Force:	3750 DaN
Max. torque on key:	60 daN.m.
Material:	Steel
Weight	661kg (approx.)

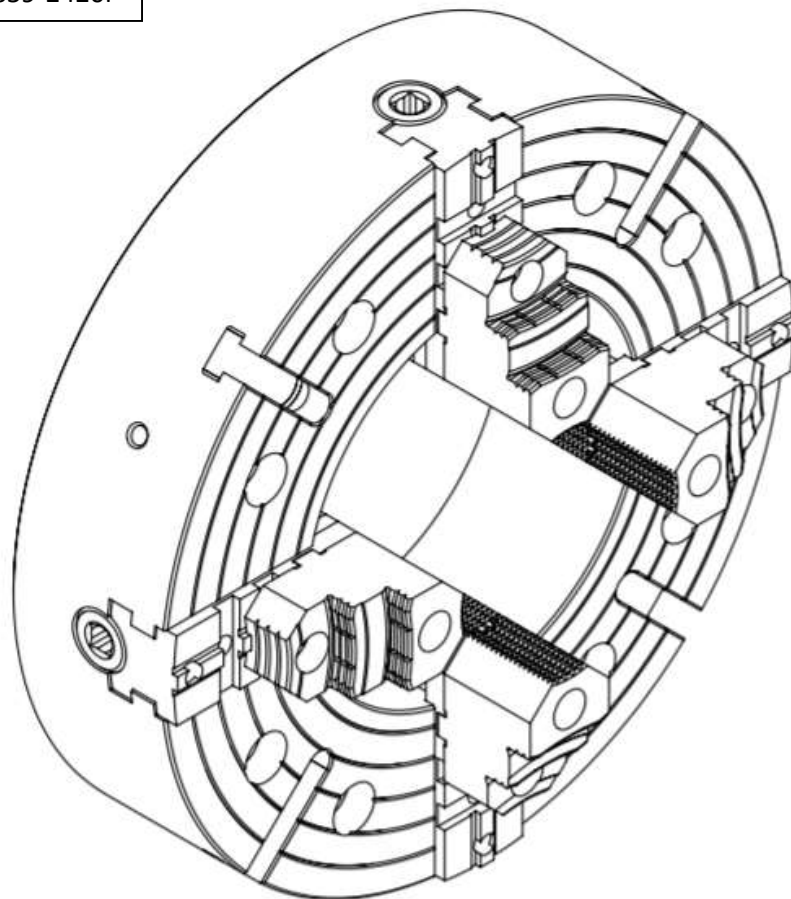
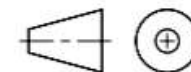

3-859-2420P

