

CONT. TEFC 213TC

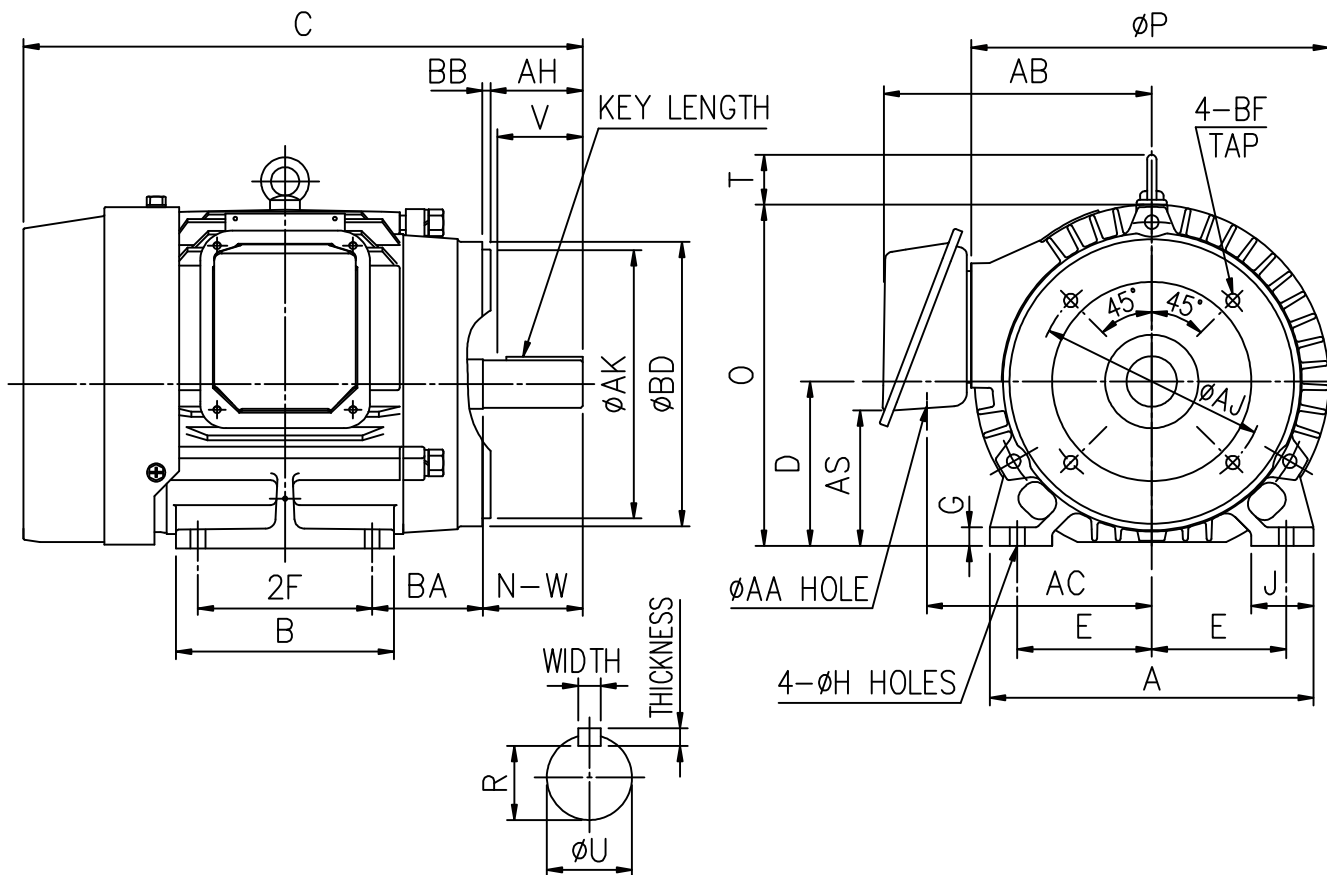

A	B	C	D	G	J	O	P	T	AJ	AK	BD	BB	BF	AH	MOUNTING			
															E	2F	H	BA
10.23	6.89	17.94	5.25	0.65	1.97	10.84	11.20	1.65	7.250	8.50	9.00	0.25	1/2-13	3.12	4.25	5.50	0.41	3.50

CONDUIT BOX				KEY			KEYSEAT	SHAFT EXTENSION			BEARING NO.		APPR. WT.
AA	AB	AC	AS	WIDTH	THICK- NESS	LENGTH	R	N-W	U	V	D.E	O.D.E	
1.38	8.39	7.2	4.4	0.312	0.312	2.375	1.201	3.38	1.375	3.30	6308ZZ	6208ZZ	152 lb

- NOTE:**
1. TOLERANCE OF SHAFT END DIAMETER U: +0.000, -0.0005
 2. TOLERANCE OF SHAFT CENTER HEIGHT D: +0.000, -0.03
 3. DIMENSION R TOLERANCE: +0.000, -0.015
 4. DIMENSION AK TOLERANCE: +0.000, -0.003
 5. DIMENSION V IS LENGTH OF STRAIGHT PART OF SHAFT.

C-FACE